

**Description:**

NFPA 99 compliant quadplex dry rotary claw medical vacuum package. Three piece vertical stack mount system is designed for single point connections. All systems are thoroughly tested prior to shipping. This system ships with:

- Inlet and discharge threaded flex connectors
- Hard copy and CD of O&M manuals

Package Details:

Quadplex medical vacuum system, consisting of four continuous duty, dry rotary claw, air cooled vacuum pumps. The vacuum pumps, vacuum receiver and control panel shall be factory assembled in a three piece package, pre-plumbed and pre-wired for single point connections. The package includes: 5.0 micron inlet filters, vibration isolation feet under each pump, exhaust and intake manifold plumbing with flexible metal vibration isolators, pump isolation valves, sight gauge, 3 valve by-pass and main system shutoff valve with flexible metal isolator for connecting to piping system. The package meets or exceeds NFPA 99 current edition.

Dry Rotary Claw Vacuum Pump:

Each medical vacuum pump shall be a non-contact, friction free dry rotary claw. The direct shaft-driven claws generate vacuum efficiently and economically, are ideal for WAGD applications, and have a long service life. No lubrication or sealing fluid shall be required inside the vacuum chamber resulting in low maintenance service and cost. In comparison to other vacuum technologies, they offer safe and reliable operation at fairly low noise levels. The rotary claw shall be a single stage, positive displacement, continuous duty type vacuum pump, capable of operating continuously through its full range up to 28.4" Hg. Each vacuum pump shall be equipped with an inlet check valve, anti-suck back valve, and vacuum inlet filter with a 5.0 micron replaceable element. Each vacuum pump is air cooled and no water shall be required for normal operations.

Electric Motor/Drive:

Each vacuum pump shall be direct driven by a 3,600 RPM C-face, totally enclosed, fan cooled, TEFC electric motor. Motor shall be 208-230/460 volt, three phase with a service factor of 1.15.

**Vibration Isolation:**

Each pump and motor assembly shall be mounted to the base frame/tank with seismically restrained vibration isolators.

Vacuum Receiver:

The tank shall be constructed in accordance with A.S.M.E. standards and shall be equipped with 3 valve by-pass piping, vacuum gauge, double valve drain system and sight gauge.

Standard Control Panel:

The system includes a quadplex control panel in a NEMA 12 enclosure. The control panel is UL 508 listed and is designed to operate an NFPA 99 compliant medical vacuum system. The panel includes: individual through-the-door disconnects for each motor, motor circuit breakers, magnetic starters, adjustable motor overload protection, dual control voltage transformers, alternating circuit, hand-off-auto switches, auto/lead pump selector switch, power on light, high temperature lights, transformer failure light, pump run lights, vacuum switches and alarm contact connection points. The control panel will start up immediately after power failure and no boot-up time is required.

Optional:

- Galvanized tank.
- Touch-Screen Interface Control System (HMI/PLC) with built-in ethernet, system monitoring, maintenance alerts and multiple protocols for facility automation systems.

Dry Rotary Claw Vacuum Package Quadplex vertical Stack Mount 8.7, 10 & 15 HP

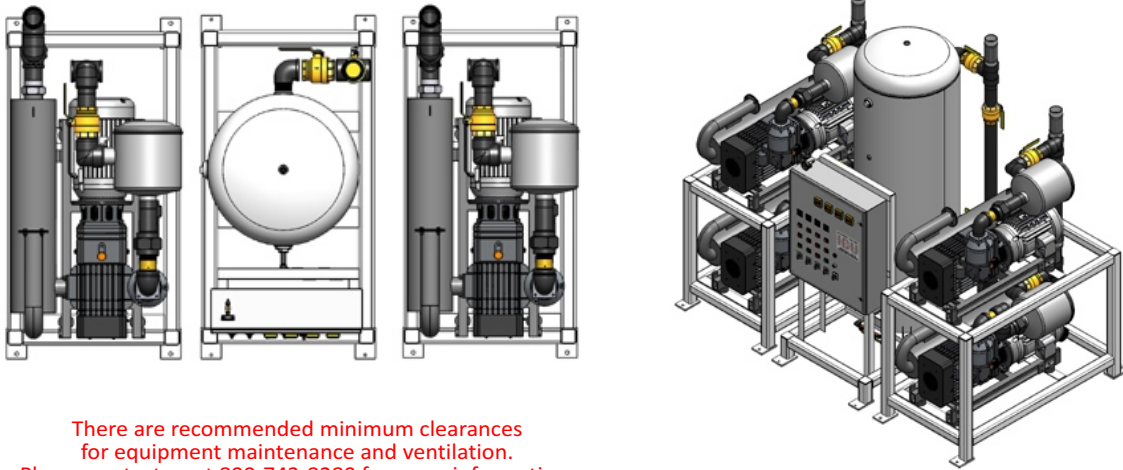

There are recommended minimum clearances for equipment maintenance and ventilation. Please contact us at 800-743-8280 for more information.

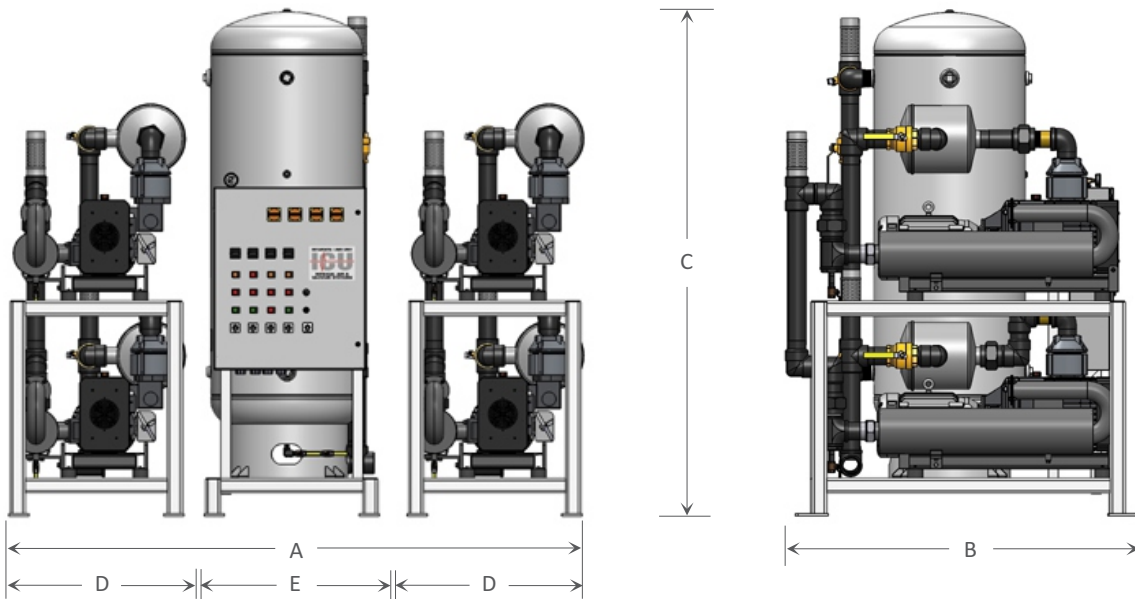

SHOWN: Quadplex 15 HP, 200 gallon, vertical stack mount, standard dry rotary claw configuration.

NFPA Compliant Medical Vacuum Package - Technical Data

Model Number	Tank Gals	HP		SCFM @19" HG		dB(A) (3)	System FLA			BTU HR	Dimensions					NPT In	NPT Out	Weight (LBS)
		each	pkg	each (1,2)	pkg		Level	208V	230V		460V	A	B	C	D			
V78M-QST-4VS	120	8.7	34.8	77.0	231.0	83	54	49	25	22,137	104	69.5	74.0	34.5	34.5	1.25	1.0	4,450
V78M-QST-5VS	200	8.7	34.8	77.0	231.0	83	54	49	25	22,137	104	69.5	88.0	34.5	34.5	1.25	1.0	4,530
V78M-QSH-4VS	120	10.0	40.0	89.0	267.0	84	60	52	26	25,444	104	69.5	74.0	34.5	34.5	2.00	2.0	4,470
V78M-QSH-5VS	200	10.0	40.0	89.0	267.0	84	60	52	26	25,444	104	69.5	88.0	34.5	34.5	2.00	2.0	4,545
V78M-QSJ-5VS	200	15.0	60.0	129.0	387.0	85	78	72	36	38,167	104	69.5	74.0	34.5	34.5	2.00	2.0	4,500
V78M-QSJ-6VS	240	15.0	60.0	129.0	387.0	85	78	72	36	38,167	104	69.5	88.0	34.5	34.5	2.00	2.0	4,675

1. Vacuum pump data is shown with one pump in reserve. 2. Pump capacities are shown in SCFM (Standard Cubic Feet per Minute). 3. dB(A) levels are shown as only one pump running. 4. Data is shown with equipment running at normal operating conditions with a maximum ambient temperature of 105°.