

Description:

NFPA 99 compliant triplex oil-less rotary scroll medical air package. One piece tank mount system is designed for single point connections. All systems are thoroughly tested prior to shipping. This system ships with:

- Inlet and discharge threaded flex lines
- Hard copy and CD of O&M manuals

Package Details:

Tank mounted one piece medical air system including: Six each scroll air cooled oil-less air compressors with air cooled aftercoolers, automatic separator drains, and high temperature discharge switch, and 5.0 micron air inlet filters with connections for remote intake. Six each TEFC electric motors, ASME tank with interior corrosion resistant lining, 3 valve bypass, sight gauge, electric automatic tank drain with manual drain valve and pressure safety valve. Dual desiccant air dryers with isolation valves, pre-filters with differential indicators and auto drains, 2-stage final filters with differential indicators. Pressure regulators with oxygen cleaned gauges, CO and dew point monitors with audible/visual alarm and contacts for remote alarm and duplex NEMA 12 control panel. The package is pre-wired and pre-plumbed for single point connections.

Scroll Compressor Pump:

The medical air compressors are a rotary scroll, oil-less, integral air-cooled, single-stage 100% continuous duty rated design. Tip seals made of a composite PTFE material rated for 10,000 hours of operation. Each compressor shall be packaged with high temperature shutdowns, and air-cooled after-coolers with automatic separator drains and check valves. The quiet, reliable and space saving Scroll Compressors are belt driven.

Electric Motor/Drive:

Each compressor is belt driven by a dedicated Premium Efficient 1,750 RPM totally enclosed, fan-cooled (TEFC) electric motor with a rigid base. Motor is 208-230/460 three phase with a service factor of 1.15.

Vibration Isolation:

Each pump and motor assembly is mounted to the base frame/tank with seismically restrained vibration isolators.

Air Receiver:

The tank shall be constructed in accordance with ASME standards and include an interior resistant lining, 3 valve bypass, sight gauge, electric/automatic solenoid tank drain with manual drain valve and pressure safety valve.

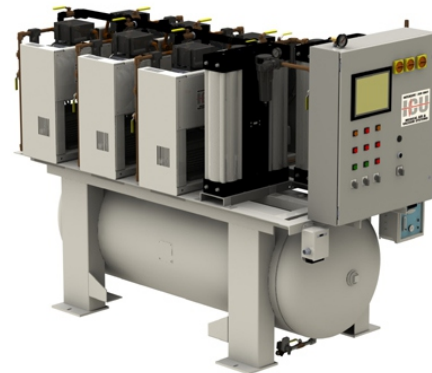

Desiccant Air Dryers with Filters & Regulators:

Duplex desiccant dryers with demand control purge saver. Each desiccant dryer is sized to meet the rated system flow capacity while maintaining pressure dew point in accordance with NFPA 99. Each dryer assembly is isolated with full port ball valves for easy isolation and maintenance. Each dryer includes: 0.01 micron pre-filters with differential indicators and auto drains, 2-stage final filters with a first stage rating of 3.0 micron, a secondary stage rating of 0.03 micron and a differential indicator. The dryers also include pressure regulators with oxygen clean gauges.

Dew Point & CO Monitors:

The air system includes digital dew point and carbon monoxide monitors. Each monitor shall include audible and visual alarms, adjustable alarm set points and dry contacts for remote alarms.

Standard Control Panel:

The system includes a triplex control panel in a NEMA 12 enclosure. The control panel is UL 508 listed and is designed to operate an NFPA 99 compliant medical air system. The panel includes: individual through-the-door disconnects for each motor, motor circuit breakers, magnetic starters, adjustable motor overload protection, dual control voltage transformers, alternating circuit, hand-off-auto switches, auto/lead pump selector switch, power on light, high temperature lights, transformer failure light, compressor run lights, pressure switches and alarm contact connection points. The control panel will start up immediately after power failure and no boot-up time is required.

Optional:

- Touch-Screen Interface Control System (HMI/PLC) with built-in ethernet, system monitoring, maintenance alerts and multiple protocols for facility automation systems.

Oil-less Rotary Scroll Compressor Package - Triplex Tank Mount 10 HP - Desiccant

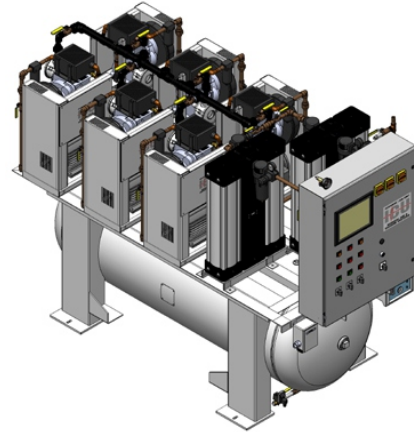
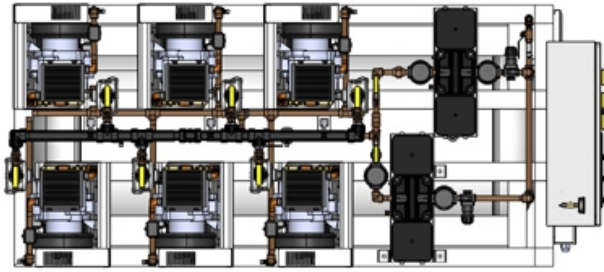

There are recommended minimum clearances for equipment maintenance and ventilation. Please contact us at 800-743-8280 for more information.

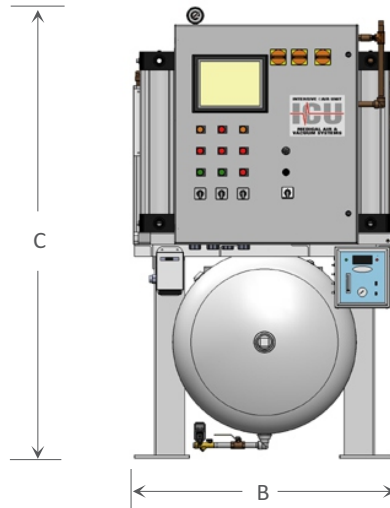
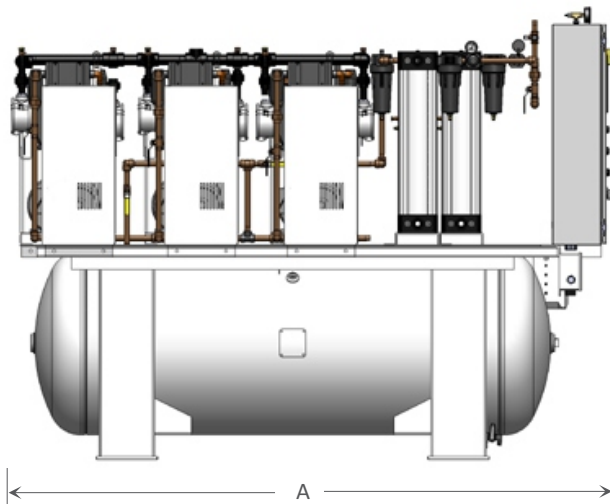

SHOWN: Triplex 10 HP, 240 gallon, horizontal tank mount, Scroll configuration with optional PLC shown.

NFPA Compliant Medical Compressor Package - Technical Data																
Model Number	Tank Gals	HP		SCFM @50 ^(1,2)		dB(A) ⁽³⁾	System FLA			BTU HR	Dimensions			NPT In	NPT Out	Weight (LBS)
		each	pkg	each	pkg	Level	208V	230V	460V		A	B	C			
A72M-TTH-6HE-D	240	10.0	30.0	29.60	59.20	74	82.2	75.6	37.8	50,900	99.5	42.5	73.0	1.50	0.75	1,954

1. Compressor data is shown with one pump in reserve. 2. Compressor capacities are shown in SCFM (Standard Cubic Feet per Minute). 3. dB(A) levels are shown as only one pump running. 4. Data is shown with equipment running at normal operating conditions with a 105° maximum ambient temperature.